

XXVII. *Account of Experiments made at Holyhead (North Wales) to ascertain the Transit-Velocity of Waves, analogous to Earthquake Waves, through the Local Rock Formations.* By ROBERT MALLETT, C.E., F.R.S.

Received June 18,—Read June 20, 1861.

IN my "Second Report on the Facts of Earthquake Phenomena" in the Report of the British Association for 1851, the transit-velocities were experimentally determined of waves of impulse produced by the explosion of charges of gunpowder, and these velocities shown to be

In wet sand . . . . .	824·915 feet per second,
In discontinuous granite . . .	1306·425 feet per second,
In more solid granite . . . .	1664·574 feet per second,

the range of sand employed having been that of Killiney Strand, and of granite that of Dalkey Island, both on the east coast of Ireland. These results produced some surprise on my own part as well as on that of others,—the transit-velocities obtained falling greatly below those which theory might have suggested as possible, based upon the modulus of elasticity of the material constituting the range in either case.

I suggested as the explanation of the low velocities ascertained, that the media of the ranges (like all the solids constituting the crust of the earth) were not in fact united and homogeneous elastic solids, but an aggregation of solids more or less shattered, heterogeneous, and discontinuous, and that to the loss of *vis viva*, and of time, in the propagation of the wave from surface to surface, was due the extremely low velocities observed.

The correctness of this view, and a general corroboration of the correctness of the experimental results themselves, have since been made known by the careful determinations by NÖGGERATH and SCHMIDT respectively, of the transit-velocities of actual earthquake waves in the superficial formations of the Rhine country and of Hungary, and by myself in those of Southern Italy, all of which present low velocities coordinating readily with my previous experimental results.

In the Report above mentioned, I suggested the desirableness of extending the experimental determination of wave-transit to stratified and foliated rocks, as likely to present still lower velocities than those obtained for shattered granite, as well as other important or suggestive phenomena. The operations in progress at the Government quarries at Holyhead (Island of Anglesea, North Wales), of dislodging vast masses of rock by means of gunpowder for the formation of the Asylum Harbour there, appeared to me to present a favourable opportunity of making some experiments upon the

MDCCLXI.

4 v

stratified rock formations of that locality, by taking advantage of the powerful explosions necessary at the quarries. These quarries are situated (see Map, Plate XX.) on Holyhead Mountain on its N.E. flank, in metamorphic quartz rock, and in 1852 (a vast mass of material having been already removed) presented a lofty, irregular, and nearly vertical scarp, reaching to 150 feet in height above the floor of the quarry in some places.

From this wall of solid rock the process of dislodgement was continued, not by the usual method of blasting, by means of small charges fired in jumper holes bored into the rock, but by the occasional explosion of large mines, containing at times as much as *nine tons* of gunpowder lodged in one or in three or more separate foci, deep within the face of the cliff, and formed by driving "headings" or galleries from the base of the mural face into the rock. From the charges of powder placed in bags at the innermost extremities of these headings, which were stopped up by several feet of "tamping" of stone, rubbish, and clay, conducting-wires were led out to a suitable and safe distance; so that on making by these the circuit complete between the poles of a powerful SMEE'S galvanic battery, a small piece of thin platinum wire adjusted within the charge of gunpowder became heated, and ignited the powder. The explosion thus followed instantaneously the making contact between the poles of the battery.

Experience has enabled the engineers charged with the work so exactly to proportion the charge of powder to the work it is intended to perform in each case, that no rock is thrown to any distance; the whole force is consumed in dislocating and dropping down to its base as a vast sloping talus of disrupted rock and stone the portion of the cliff operated on; in fact, at the moment of explosion the mass of previously solid rock seems to fall to pieces like a lump of suddenly slacked quicklime. The shock or impulse, however, delivered by the explosion upon the remaining solid rock, behind and around the focus, and propagated through it in all directions outwards, as an elastic wave of impulse, was at an early stage of the operations remarked to be so powerful, that it could be felt distinctly in the quaking of the ground at distances of several hundred yards, and was sufficient even to shake down articles of delf ware from the shelves of cottages a long way off from the quarries.

Early in 1853 I visited those quarries, and examined generally the adjacent locality and rock formations, and having satisfied myself that these operations could be made available, I applied to my distinguished friend, the late lamented Mr. RENDELL, C.E., the engineer in chief of the Asylum Harbour, and readily obtained from him permission to make such experiments as should not interfere with the progress of the works.

The prosecution of these experiments having been favourably represented to the British Association for the Advancement of Science, and to the Council of the Royal Society, a sum of money was voted by each of these bodies respectively, and placed at the author's disposal, with the desire that he should undertake and conduct the experiments.

It was not, however, until the summer of 1856 that my own avocations, and various preliminaries, allowed any progress to be made with the experiments themselves. Ne-

gotiations had to be entered on with several parties; with the occupier of some land at Pen-y-Brin, about a mile to the east of the quarries, where the most suitable spot for placing the seismoscope (the observer's station O, see Map) was found, for permission to enter his land, and level down to a horizontal surface the face of the rock, here occupying the surface of the ground, and to erect an observer's shed over it; and with the Electric Telegraph Company, for the hire of insulating telegraph poles and wires, and for their erection over the range intervening between this spot and the highest reach of the quarry hill.

As these great blasts are fired only occasionally and at uncertain intervals, and being prepared *must be fired without postponement*, and within a given hour of the day, namely, during the workmen's dinner hour (12 to 1 P.M.), when the quarries are clear of men, and therefore safe from accident, it became at once obvious that very frequent journeys, both on my own part and on that of such assistants as I should require, would have necessarily to be made to and from Holyhead; and to economize as much as possible the large expenditure that must thus arise, I applied to the City of Dublin Steam Packet Company, and to the Chester and Holyhead Railway Company, through their respective Secretaries, representing the scientific character of the undertaking, and requesting on their parts cooperation, by their permitting myself and my assistants, with any needful apparatus, to pass free to and from Holyhead by their respective vessels from Kingstown Harbour. After much fruitless correspondence I regret to say that both these Companies refused to render any assistance whatever, a boon the refusal of which greatly increased the expenditure for these experiments. Lastly, I placed myself in communication with Messrs. RIGBY, the contractors of the vast works of the Quarries and Harbour, and in August 1856 received from them the assurance of every assistance that they could afford consistently with the prosecution of the works. To them, to Mr. R. L. COUSENS, C.E., the acting engineer for their Firm on the works, and to Mr. G. C. DOBSON, C.E., chief engineer on the work under Mr. RENDELL (since under Mr. HAWKSHAW), my thanks are due for the best and most cordial assistance upon all occasions.

The position for the observer's station and seismoscope upon the levelled floor of rock at Pen-y-Brin having been fixed upon, the first operation necessary was to obtain an accurate section of the surface in the line between that and the quarries, a geological section of the rock formations along the same line, and with precision the exact distance in a straight line, from some fixed point adjacent to the quarries, to the observer's station. The fixed point chosen at the quarries was the flagstaff at the bell, which is rung whenever a blast is about to be fired, this being so placed that from it measurements and angular bearings with the line of range, OW (Map), from the various sites of future explosions could readily be made, and thus the exact distance of each focus of explosion (to be hereafter experimented on) from the seismoscope at O ascertained, the flagstaff always remaining undisturbed as a fixed terminal at the quarry end of the range.

The whole surface, O to W, was carefully levelled over, and the distances chained, as

given in Plate XXI. Section I. The roughness of the ground and its inclination, however, rendered direct measurement of the range of wave-path with sufficient accuracy impracticable, and it was found necessary to obtain it trigonometrically. For this purpose a base-line of 1432 feet in length was measured off along the rails of the tram-road which connects the quarry with the east breakwater, between the points A and B (Map, Plate XX.), where the road fortunately was found straight and nearly quite level.

This was measured with two brass-shod pine rods, each of 35 feet in length, of the same sort, and applied in the same manner, as I used in 1849 for measuring the base of one mile on Killiney Strand, for the particulars of which the "Second Report on Earthquakes," &c., Report. Brit. Assoc. 1851, p. 274, &c., may be referred to. The base was measured forwards and backwards, with a result differing by less than 3 inches. The flagstaff at the spot marked W in the Map, is not visible from the observer's station, owing to some intervening houses and other objects; a staff was therefore set up at S upon the hill-side. The point O was connected by angular measurements with the extremities of the measured base A and B; the triangles OBS and OSW were then obtained, whence that OBW was arrived at, from which, finally, the distance OW (the constant part of the range) was ascertained to be = 4584.80 feet. The triangle OBW was used as a check upon that OSW, as the angles at O, S, and W had to be taken, owing to local circumstances, smaller than is desirable. The lengths of the side OW obtained from the two triangles separately closely agreed; and as a further check, the side SW, which gave, trigonometrically, a length of 671.07 feet, when actually measured as a base of verification, gave 672.05 feet.

I was also enabled to connect the side OS with a trig point P, upon the western breakwater, and another at R, the positions of which are defined upon the accurate surveys of the harbour in Mr. DOBSON'S, C.E., possession, as a further means of verification; we may therefore view the length of the constant part of the range between the observing station and the flagstaff, its other permanent terminal, as equal to 4585 feet, neglecting fractions.

The base of the staff at S was found to be 68.78 feet above the level of the horizontal surface of the rock at Pen-y-Brin (the observing station O), and the base of the flagstaff at W is 5.70 feet above the same point O. The levelled surface of rock at O is 84 feet above the mean tide-level of the sea in the Asylum Harbour; and the average rise and fall of spring tides at Holyhead is 18 feet; the line of rock, therefore, through which the range passes is, except as respects surface water, permanently dry to a considerable depth. The majority of the headings are driven into the face of the quarry cliff horizontally, at from 10 to 20 feet above the level of the floor of the quarry, which is on nearly the same level as the point W. Hence, practically, the actual range of transmission through the solid rock, of the impulse from each heading when fired, to the seismoscope at the observer's station, may be considered as a horizontal line, and no correction of distance is required for difference of elevation at the two extremities of the observing-range in the deduction of our results.

The Island of Holyhead, as may be seen on consulting the sheets (Nos. 77 and 78) of the Geological Survey of England and Wales, consists mainly of chloritic and micaceous schist or slate, and of quartz rock. The latter forms the N.W. portion of the island; and in it alone are situated the Harbour quarries, upon the side of Holyhead Mountain (as it is called), the same rock rising to its summit, which is 742 feet above the sea, mean tide-level. The junction of the quartz and of the schist or slate rock runs in azimuth N. 24° E. where it crosses the line of our range, which it intersects at an angle horizontally of 73° 30'.

The schist or slate rocks here overlie the quartz, abutting against the flank of the latter, apparently unconformably, and having an inclined junction whose dip is towards the S.E. and probably, at the place where our range intersects, having an angle of dip of about 65° with the vertical. The point of junction is situated about 900 feet from the flagstaff W; so that about 2100 feet, on the average of our actual ranges, lay in quartz rock, and the remainder, or 3750 feet, in the schist or slate formation, taking the mean total range at 5851 feet. The general tendency of the schist is to a dip to the N.W., varying from 5° to 20° from the horizontal; but no well-defined bedding is obvious, either in it or in the quartz.

Lithologically, the quartz rock consists of very variable proportions of pure white, light grey, and yellowish quartz, and of white, or yellowish white, aluminous and finely micaceous clays. In many places the mass of the rock presents to the lens almost nothing but clear and translucent quartz, breaking with a fine waved glassy fracture, striking fire with steel, extremely hard and difficult to break, and showing a very ill-defined crystallization of the individual particles of quartz, which have all the appearance of pure quartzose sea-sand that had become agglutinated by heat and pressure coacting with some slight admixture of the nature of a flux.

The specific gravity of such portions, as determined for me by my friend Mr. ROBERT H. SCOTT, A.M., Secretary to the Geological Society of Dublin, is 2.656. From this the rock passes in many places into a softer and more friable material, consisting, when minutely examined, of the same sort of quartz-grains, with a white pulverulent clay containing microscopic plates of mica disseminated between them. This fractures readily, but will still strike fire with steel; and its average specific gravity is 2.650.

Both, but particularly the harder variety, are found often in very thick masses of nearly uniform quality, separated by great master-joints, though scarcely to be considered as beds; but usually the mass, viewed in the large, is heterogeneous in the highest degree, massive and thick in one place, full of joints and even minutely foliated in others, and everywhere intersected by thin and thick veins of harder quartz, agglutinated sand and, elsewhere, friable sand, and of soft sandy clay.

Both the quartz rock and the schist of the island are intersected by three great greenstone dykes (of inconsiderable thickness, however), none of them interfering with our range, and by one or more *great* faults, all of which run through nearly the whole island in a N.W. and S.E. direction, and by numerous other minor faults and dislocations, some

of which may be seen as cutting through our line of range at *f*, *g*, *k*, *l*, in Plate XX. Section II.

At a short distance *behind* the quarry cliff, and seat of our several explosions, a great clay dyke occurs in the quartz rock—a wall, in fact, of about 20 feet in average thickness, running in the direction marked on the Map (Plate XX.), and with a dip of only about 20° from the vertical. This consists of strongly compacted clay, nearly pure white, and more or less mixed with fine sand and grains of mica, but cannot be called rock, though continually passing into stony masses. Lying as it does in rear of our experimental headings, it was of some value, as presenting a dead solid *anvil* to the pulse from each explosion, in the contrary direction to that of the observed wave of impulse, and hence causing a larger and more distinctly appreciable wave to be transmitted in the direction towards the seismoscope.

The schist rock, in colour, passes from fawn-colour and light greenish ashen grey into a rather dark tea-green. It owes its colour to disseminated thin layers of chlorite, and probably of black or green mica in minute scales, between which are thicker layers of quartz, presenting identically the same mineral characters as those of the quartz rock beneath. These layers, owing to the small relative hardness and cohesion of the chlorite and mica, present planes of weakness and of separation; the rock is, in fact, everywhere thinly foliated, the average thickness of a plate seldom exceeding 0·2 of an inch, and averaging about one half that thickness. These foliations are twisted, bent, doubled up, and distorted in every conceivable way. The contortions are often large, the curves having radii of some feet, with minor distortions within and upon them; but most commonly they are small; so that it is rare to get even a hand specimen presenting flat and undistorted foliations, while, quite commonly, hand specimens may be found presenting within a cube of 4 or 5 inches two or three curves of contrary flexure, often in all three axes, and with curvatures short, sharp, and abrupt, almost angular. There is a general tendency observable in the greater convolutions to conform more or less to the surface-contour of the country; so that the largest and flattest folds are found to occupy, with an approach to horizontality, the topmost portions of the great humps or *umbos* of schist rock that form the characteristic of the landscape, and so rolling off in folds smaller, steeper, and more convoluted towards the steeper sides, as though these masses had slipped and doubled upon themselves when soft and pasty.

Occasionally, however, where deep cuttings have exposed the interior of such surface-knolls, it is found sharply convoluted and twisted in all directions, and without any relation to the existing surface of the country. Everywhere this mass of minutely structured, convoluted, and foliated rock is cut through by joints of separation, with surfaces in direct and close contact, and by thin seams and veins of hard and sometimes pretty well crystallized quartz, now and then discoloured by oxide of iron, and with minute cavities filled with chlorite and mica, and with others of agglutinated quartzose sand, whose bounding-lines pass off rapidly, but *gradatim*, into the prevailing substance of the rock. It is by no means of equal hardness. Some portions (and these occur with-

out any order or traceable relationship throughout the mass) are much thinner in the foliation, and the layers of chlorite and mica nearly as thick as those of the intervening quartz, both being so attenuated, that to the naked eye the edge of the foliation presents only a fine streaky appearance of lighter and darker green-grey tint. The softest, however, readily strikes fire with steel; and throughout the whole mass of the rock, for the length of our range, it is so hard, coherent, and intractable as to be only capable of being quarried by the aid of gunpowder and with very closely-formed jumper holes.

The specific gravity of the densest portions of the schist rock reaches 2·765, that of the softer averages 2·746. When the rock, whether hard or soft, is broken, so that the applied surfaces of the foliations are visible, they are often found glistening and greasy to the feel, from flattened microscopic scales of mica, or possibly of talc.

The quartz rock fractures under the effect of gunpowder into great lumpy masses, with much small rubbish. The schist under, that, from jumper-hole blasts, breaks up into coarse, angular, knotted and most irregular wedges, the foliations breaking across in irregularly receding steps, and (throughout our range at least) a stone with a single flat bed being perhaps unprocurable. Both rocks are absolutely dry, or free from all perceptible percolations of surface-water issuing as springs, nor does the rain penetrate their substance by absorption for any appreciable depth,—both indications of their generally compact structure.

The faults with which our range is intersected in four places, at a horizontal angle of about 75°, are not far from vertical, dipping a few degrees to the N.W. They occur at the points marked *f*, *g*, *k*, *l*, on the Geological Section (Plate XXI. Section II.); and the disturbed and shattered plate of rock between each pair respectively appears to have sustained a downthrow (or the rocks at either side the contrary) of a few feet, 10 to 12 probably. The surfaces of the walls of those faults, so far as I can judge from rather imperfect superficial indications, appear to be in close contact; and such is the character of all the small faults that intersect the formation hereabouts.

I have been thus tediously minute in describing the character of the rocks throughout our range because, if experimental determinations of earth-wave transit are to become useful elements of comparison, in the hands of the seismologists of other countries, with the observed transit-times of natural earthquake-waves, and a means of controlling such observations, it is essential that the means be afforded of accurately comparing the rock formation traversed in all cases.

From what has been described, it will be remarked that the rock here chosen for experiment presents in the highest degree the properties capable of producing dispersion, delay, and rapid extinction of the wave of impulse, so far as its structure is concerned, although the modulus of elasticity of a very large proportion of its mineral constituents (silex) is extremely high, and its specific gravity as great as that of Dalkey granite. Added to its minutely foliated and mineralogically heterogeneous character, with its multiplied convolutions, we have five great planes of transverse separation in the range, one of these forming the plane of junction of the quartz and schist, with

innumerable minor planes of separation at all conceivable angles to each other in both rocks; and yet we have highly elastic and dense materials forming the substance of both rocks, and their general mass remarkably free from open veins, fissures, or cavities.

We have also two different rocks, the one transmitting the impulse into the other, yet neither so widely differing from the other in molecular and other physical characters as to make any great or abrupt effect upon the wave at the junction probable. In fact, widely to the first glance as the quartz rock and the schist rock appear to differ, there is less real distinction of physical character between them than would be supposed: both are composed of the same siliceous sand, in about the same size of original grains, variously enveloped, in the one in chlorite and mica, and in the other in white or grey clay and mica; both have, in ancient geological epochs, doubtless derived their materials by degradation and transport from a common source as respects their main constituent, the siliceous sand; both have been submitted to approximately similar pressures, and probably like temperatures; and the agglutinating flux has probably been mainly the same for both, viz. the minute proportions of alkalis derived from the waters of an ancient ocean.

The main difference in physical structure, viewed upon the broad scale, between the quartz rock and the slate is this (as regards our experiments):—that the great joints and planes of separation on the whole approximate to *verticality* in the former, while in the latter, with the exception of some larger faults and dykes, the planes of separation are twisted and involved in all directions, but tend more to approach *horizontality*.

More interesting conditions could thus scarcely be found for experimental determination of the transit-rate of earth-waves, or more desirable for future comparison with that of earthquake-waves themselves; much more instructive, indeed, were the actual conditions than if the means of experiment presented by these vast quarry operations had been in the most regular, undisturbed, and horizontal stratified rock, like some of the mountain limestone of Ireland, or the finest and densest laminated roofing-slates of Wales. In such ranges we can predict that the transit-velocity would at least be high. In the medium chosen for these experiments it was impossible even to guess what it might be found.

I proceed to describe the instrumental arrangements made for the observation of the impulse-wave transmitted from the blasts chosen, and for the determination of the transit-time along the range of wave-path. Over the surface of solid rock that had been chiselled down to a level tabular surface at (O) Pen-y-Brin, a timber shed was erected of sufficient size to place the observer, an assistant, and all the instruments proper to that spot, under cover and secured from the wind. The side to the N.W. was open, to permit of observation along the line of range, with the means of partially closing it in high winds.

Along the line of the boundary-wall of the railway next Pen-y-Brin, and thence along up to the highest and most distant point of the quarry cliffs, a line of telegraph-posts was planted; and upon these, two properly insulated iron wires were hung, in such a



manner that at any point along their length over the quarry cliffs, a pair of branch wires (covered with gutta percha) could be led off, and in like manner another pair to the apparatus in the observing-shed at Pen-y-Brin, thus giving the means of galvanically connecting the extremities of the range, in any way that might be required.

The mines in use at the quarries frequently consist of two, three, or four separate chambers and charges, which are all fired simultaneously (see Plate XXII.); but each charge is fired by a distinct pair of wires, igniting a fine platinum wire interposed in the circuit and immersed in one of the powder-bags. The arrangement of this platinum wire in its hollow wooden frame to prevent disturbance, and its connexion with the large conducting-wires, are practically the same as those adopted by me in 1849 at Killiney, and will be found fully described in "Second Report on Earthquakes," &c., Report of British Association for 1851, p. 277.

When several charges are to be fired simultaneously, all the electro-positive wires from each chamber are collected into one mercury-cup in connexion with one pole of the battery, and all the electro-negative wires into another mercury-cup. Upon making contact between the latter and the second pole of the battery, the current at the same moment ignites all the platinum wires passing through each pair of wires as a separate conducting-path. This method requires considerable battery power, but is the only certain or reliable one for firing simultaneously a number of separate charges. When an attempt is made to pass the current from one pole of the battery through a single pair of wires, and through all the fine platinum priming-wires in succession to the return pole, there is extreme risk that the first or second platinum priming, owing to its attenuated section of wire (in virtue of which indeed alone it becomes ignited at all), may interpose so much resistance to the current as to prevent the ignition of the third, or fourth, or other subsequent primings, or that the first priming-wire may get absolutely fused or broken by the first-ignited powder, and so cut off all communication with the others before they have been heated sufficiently.

A neglect of this obvious consequence of OHM'S law of resistance appears to have been the cause of failure very recently, in an attempt to ignite a number of mines of demolition, simultaneously, at Chatham. From the great magnitude of the charges frequently fired at Holyhead, and the very serious consequences that failure of ignition would involve, the battery power habitually employed is wisely of superabundant power. It consists of a GROVE'S battery of thirty-two cells, each exposing 96 square inches of platinum element. It is but justice to my friend Mr. R. L. COUSINS, C.E., to whose assistance in these experiments I am so much indebted, to add that during the several years he has controlled these vast blasting-operations a single failure of ignition has never occurred.

For the above reasons, and from the necessity that in the event of any failure of such apparatus as I might require for experiment, in making contact and firing the mine at a given moment, the power should still be reserved to Mr. COUSINS to fire it directly afterwards in the usual way, so as not to interfere with the works, I was led, finally,

to devise the following magneto-galvanic arrangement, by which, at a signal given from the summit of the quarry cliff (where the firing-battery is usually placed, nearly above the mine or heading then to be fired, and at a safe distance back from the edge of the cliff, usually about 100 yards) that all was ready, I should myself, stationed at the observing-shed (O), be enabled to complete the contact and fire the mine, and do so in such a way as to register by means of the chronograph the interval of time that elapsed between the moment that I so made contact (or fired) and the arrival of the wave of impulse through the rocks of the range or wave-path, when made visible by, and observed by me in, the seismoscope.

For this purpose such an arrangement was required as, upon contact being made by me at the observing-shed (O), should set in motion such a contrivance, situated upon the quarry cliff, at the remote end of the telegraph wires, as should there instantly close the poles of the great (GROVE'S) firing-battery and so fire the mine, and in the event from any cause of this result not taking place at the preconcerted moment, that then it should be free to Mr. COUSENS or his assistants to close the poles of the firing-battery by hand in the ordinary way.

In Plate XXIII., in which (fig. 1) this arrangement is figured (without reference to scale), A is one of the headings seen in the cliff-face at part of the quarries. Above the cliff at B is placed the GROVE'S firing-battery; the conducting wires from its poles pass down the face of the cliff and into the heading, uniting at the platinum priming-wire in the midst of the charge of powder, the further end of the wires terminating in mercury-cups at the contact-maker C (about to be described). From the electro-magnet of the contact-maker, the two insulated wires are led along upon telegraph poles from the summit of the cliff down to the observer's station at Pen-y-Brin, where they terminate also in mercury-cups, one forming the  $\epsilon+$  and the other the  $\epsilon-$  pole of the contact-making battery E placed there. This battery consisted of six of the usual moistened-sand batteries in use for telegraph purposes.

The chronograph (D) was placed upon the levelled rock adjacent to this battery, and conveniently for its lever (*m*) being acted on by the left hand of the observer, when lying at full length upon the ground, with his eye to the seismoscope based upon the rock at F, its optic axis being situated in the vertical plane of the line of wave-path or range F A. Close to the seismoscope, and at the same level as the eyepiece of that instrument, a very good achromatic telescope was adjusted upon its stand, so as to bring the heading about to be experimented on, together with the whole face of the cliff and the firing-battery, &c., within its field,—the eyepiece of this telescope being fixed at about a distance of 6 or 8 inches from that of the seismoscope, and so that the eye of the observer, while lying at ease, and with the left hand upon the lever of the chronograph (*m*), could be instantly transferred from the one instrument to the other. In this state of things, when the proper signal (by the exhibition of a red flag) was made, and at a preconcerted time as nearly as was practicable, by those stationed at the firing-battery at B, that "all was ready," I applied my eye to the seismoscope and pressed down the lever (*m*) of the

chronograph with a sharp rapid movement; this instantly closed the poles of the contact-making battery C, causing the galvanic current to pass through the electro-magnets of the contact-maker away at the quarries at C. This directly closed the poles of the GROVE'S firing-battery at B, and fired the mine. The moment I observed the arrival of the wave of impulse propagated through the range from the explosion at A in the seismoscope at F, I withdrew my hand from the lever of the chronograph (*m*), and thus stopped the instrument, the interval of time between its having been started and stopped thus registering the (uncorrected) time of transit of the wave for the distance A F. It will now be necessary briefly to describe the several instruments separately. The seismoscope and chronograph have been already fully described in the account of the experiments made in 1849 at Killiney and Dalkey (Second Report on Earthquakes, &c., Report of Brit. Assoc. 1851), to which reference may be made.

Briefly, the seismoscope (fig. 3\*, Plate XXIII.) consists of a cast-iron base-plate, on the centre of the surface of which is placed an accurately formed trough (*b*), 12 inches long, 4 inches wide, and 2 inches deep, containing an inch in depth of pure mercury, with its surface free from oxide or dust, so as to reflect properly. The longer axis of this trough is placed in the direction of the wave-path, the base of the instrument being level. At the opposite end of the trough are placed standards with suitable adjustments; that at the end next the centre of impulse carries a tube (*c*) provided with an achromatic object-glass at its lower end, and a pair of cross wires (horizontal and vertical); its optic axis is adjusted to 45° incidence with the reflecting-surface of mercury in the trough. At the other end of the trough an achromatic telescope (*a*) with a single wire is similarly adjusted, so that when the moveable blackened cover (*ee*) is placed over the trough, &c., no light can reach the surface of the mercury except through the tube *c*. The image of the cross wires in the latter is therefore seen through the telescope *a*, clearly reflected and defined in the surface of the mercury, so long as the fluid metal remains absolutely at rest; but the moment the slightest vibration or disturbance is by any means communicated to the instrument, the surface of the fluid mirror is disturbed and the image is distorted, or generally disappears totally. The telescope magnifies 11·39 times linearly, and the total magnifying power of the instrument, to exalt the manifestation to the eye of any slight disturbance of the mercurial mirror, is nearly twenty-three times. Its actual sensibility is extremely great. In the present case, however, this was not needful, as the impulse transmitted from these powerful explosions produced in all cases the most complete obliteration of the image, and in those of the most powerful mines experimented on caused a movement in the mercury of the trough that would have been visible to the naked eye. Indeed in that of the 24th of November, 1860, the amplitude of the wave that reached the seismoscope was so great as to cause the mercury to sway forwards and backwards in the trough to a *depth* that might have been measured.

After the earth-wave has reached this instrument, a certain interval of time is necessary for the production of the wave in the mercury, and for its transit from the end of

the trough next *c*, where it is produced, to the mid-length where it is observed. This involves a correction in the gross transit-time as observed with it. For the methods by which the constant for this (seismoscope correction) was determined, I must refer again to Report of Brit. Assoc. 1851, pp. 280, 281. It amounts to 0''·065 in time; and as the effect of this will in every observation appear to *delay* the arrival of the earth-wave at the instrument, this constant in *time*, converted into *distance*, must be *added* to the rate of wave-transit otherwise obtained.

The chronograph (originally devised by WHEATSTONE) is shown in fig. 1\*, Plate XXIII. It consists, in fact, of a small and finely made clock, deprived of its pendulum, but provided with a suitable detent, shown more at large in fig. 4\*, by which the action of the weight upon it is kept always arrested, but can immediately be permitted to take place in giving it motion, upon pressing the hand quickly upon the lever *g*.

The running down of the weight causes the anchor and pallets of the escapement (*k*) rapidly to pass the teeth of the escapement-wheel (*a*), so that the clock "runs down" by a succession of minute descents, and thus the motion is practically a uniform one. It follows that as more weight is added this velocity becomes greater, and by such addition the instrument may be made to measure more and more minute fractions of time.

It registers time upon two dials (fig. 2\*), each with an index; one of these is fixed on the axis of the escapement-wheel (*a*), and its dial is divided into thirty smaller and six larger divisions. The pinion on this axis is to the wheel upon the weight-barrel (*b*) as 1:12. This carries the other index, and its dial has twelve divisions, so that one of its divisions corresponds to an entire revolution of the former one. The value in actual mean time, due to the movement of the instrument as thus recorded, requires to be ascertained by reference to a clock beating seconds, so that the number of revolutions of the index *b*, and parts of revolutions of that *a*, during an interval of, say, thirty seconds, may be determined by the mean of several experiments. For the methods of performing this with the necessary correctness, I again refer to "Second Report on Earthquakes," &c., Report of Brit. Assoc. 1851, pp. 287, 289, &c.

On the present occasion, as a considerable time elapsed between the successive experiments, during which the oil on the instrument more or less changed its state, and as some were made in summer and others in winter, it became necessary to rate the chronograph anew for each experiment, or at least to verify the former rating; for this end it was necessary to provide a suitable loud-beating seconds clock, with a divided arc to the pendulum, as none such could be procured at Holyhead. The same weight was constantly used with the chronograph; and the extreme differences found, in the rating during the several years that these experiments have been in progress, were no more than the following:—

November 1856. Value in mean time of one division of the dial (*a*) = 0·01485

May 1861. Value of same . . . . . = 0·01806

Taking for illustration the former value of the smallest division of the dial (*a*), we see

that each division of the dial ( $b$ ) is equal one revolution of the index ( $a$ ), and equal

$$0''\cdot01485 \times 30 = 0''\cdot4455,$$

and one revolution of the index ( $b$ ) equal

$$0''\cdot4455 \times 12 = 5''\cdot346, —$$

an *absolute* rate of movement of the instrument not widely differing from that employed in the experiments of Killiney and Dalkey, with which it is desirable that the present results should be comparable. Half a small division of the chronograph can be read; we therefore in these experiments possessed the means of recording time to within  $0''\cdot0074$ , or to nearly  $\frac{7}{1000}$ ths of a second.

The additional apparatus of the chronograph consisted merely of such arrangements that the releasing lever ( $g$ ), when pressed down by the hand applied to the wood insulator at  $m$ , should dip at  $i$  into a mercury-cup, and so make contact by the wires ( $b, b'$ ) between the poles of the contact-making battery (E).

It remains to describe the contact-maker (fig 2, Plate XXIII.).  $c$  is the base of the instrument of mahogany, carrying a vertical and bent arm ( $d$ ) of cast iron, into the upper forked end of which the central iron bars, of about  $\frac{7}{8}$ ths of an inch in diameter, of the electro-magnets  $\alpha, \alpha$  (seen in plan in fig. 3) are secured by a cotter. The coils of covered wire round these are continuous, the wire ( $b$ ) from the  $\varepsilon +$  pole passing at its further end from the first coil over to the second, and at the extremity of the latter passing off to the  $\varepsilon -$  pole by  $b'$ , the junctions being effected by mercury-cups in the usual way.  $n$  is a sliding piece of wood, secured upon the base  $c$ , when adjusted in place, by the screw at  $s$ ; this carries a wrought-iron lever armature ( $e$ ), whose arms are as 8 : 1, the shorter and rather heavier end being adjusted so as to be beneath the poles of the electro-magnets, and at such a distance beneath them that, upon passing the current through the coils, the magnets shall readily attract the short end of this lever, snatch it up into contact with the poles of the magnets, and in doing so depress the other or remote end of the lever. The latter extremity of the lever is provided, as seen more at large in figs. 4 and 5, with a forked pair of copper poles amalgamated, which, when depressed by the action of the electro-magnets, dip into the mercury of the cups  $f$  and  $f'$ , and in doing so close the holes of the firing-battery, the conducting wires from which ( $h$  and  $h'$ ) dip respectively into mercury-cups, which by a tube bored through the wood are in permanent communication with  $f$  and  $f'$  (cups) respectively. The lever and forked poles, &c., are provided with various screw adjustments as to position, range, &c., and a slender spring beneath the lever, ensuring that it shall not be accidentally moved by wind, or other cause, until acted on by the powerful grasp of the magnets.

This instrument was found to answer admirably well. It may be observed, in passing, that it gives the means of exploding mines at almost any distance, through telegraphic wires and by any moderate contact-making power, and may admit of valuable applications hereafter for the explosion, at a determinate instant, of mines for purposes of warfare.

It is obvious that a certain *loss of time* must occur at this contact-maker, in reference to our experiments—that in fact the total time registered by the chronograph at D is too great, by the minute interval that elapses between the arrival of the galvanic current in the coils at *a*, and the dipping of the poles *f, f* into the mercury-cups. With the same battery power at E and conducting-wires, this *delay* is practically constant. Its amount, however, required to be determined, and the *time*, when converted into *distance*, added to the gross transit-rate previously ascertained.

For this purpose the following little apparatus was employed. Its principle, though not the precise details of its construction, is shown in fig. 6, Plate XXIII. Upon a vertical steel spindle (*s*) revolving upon an agate step at bottom, and in a polished brass collar at top, a cylindric barrel is placed of 1 inch diameter, having an escapement-wheel and anchor escapement (*v*) at its lower end, all the parts being made as light as possible. Upon the upper end of the spindle a circular disc of Bristol board (cardboard), *f*, of  $12\frac{3}{4}$  inches diameter, is secured by a light screw-collar (*t*) gripping the disc firmly, so that it and the spindle must revolve together. Both the upper and under surfaces of the card-disc, for an inch or two from the circumference, towards the centre, were slightly rubbed with violin-player's *hard* rosin, and the whole, resting upon its base B, placed so that the disc should rotate horizontally. A fine *elastic* silk thread is wound a few turns round the barrel, and passing over the sheave (*r*) sustains a weight (W), by the descent of which, when required, rotation can be given to the disc, &c., the weight itself being large in proportion to the inertia of the rotating parts. By suitable changes in the disposition of the parts of the contact-maker (chiefly in getting the cast-iron arm *d*, fig. 2, out of the way), it was placed at C with respect to the disc, so that the lower poles of the electro-magnets (*a, a*) were just above the upper surface of the card-disc, and the short end of the lever armature (*e*) just below the same, the card running free in the small space between, and the centre of the magnet-poles being exactly at a radius of 6 inches from the centre of the disc. Nearly at right angles on the disc to this, the chronograph (D) was placed and firmly fixed; a fixed point (shown in part only in the fig., *g*), formed of a bit of cylindrical mahogany, with its lower end rosined, was so fixed as to be about  $\frac{1}{2}$ th of an inch above the upper surface of the disc. The lever (*m*) of the chronograph, divested of its forked pole, and having a small rectangular rod of brass substituted, was so adjusted that its sustaining spring beneath should press this brass terminal up against the under surface of the disc at *p*, directly below the fixed point or stop (*g*), and, bending the card-board there, press its upper surface into contact with the lower end of *g*.

Thus the weight W being free to descend, this arrangement at *p* acted as a detent to keep the disc from moving; but when the lever (*m*) was pressed down to start the chronograph the disc immediately became released, and began to revolve by the action of the weight W. At E the contact-making battery, or one of equal power, was placed, one of its poles being connected, through the rheostat (R), by conducting-wires with the coil of the electro-magnet (*a*) and terminating at the  $\epsilon+$  pole at the mercury-cup (*n*), which was in connexion with the other, or  $\epsilon-$  pole of the battery.

The rheostat was adjusted so that the resistance equalled that of the conducting-wires along the telegraph poles between C and D, E (fig. 1, Plate XX.). In this state of things, when the lever (*m*) of the chronograph was pressed down, the disc (*f*) instantly commenced rotating, but directly afterwards the electro-magnet (*a*), whose current was established by the first movement, attracted the lever armature (*e*) through the disc, and the latter was arrested by being gripped between the pole of the magnet and the armature. The arc of the circumference of the disc then, at the centre of the magnet-pole (*i. e.* with 6 inches radius), that was intercepted between the marked spot (*p*) whence it started and that at which it was arrested, became a measure of the time lost or elapsed between starting the chronograph at the observer's station and making contact at the firing-battery in the actual experiments. The arc thus intercepted was converted into time, from the descent of the weight (W), by the common formula  $t = \frac{\sqrt{s}}{4}$ , *s* being given and equal to  $\frac{1}{12}$ th the length in feet of the arc described by the circumference of the disc before being arrested; and this was capable of being controlled by measuring by the chronograph itself the actual time of a given number of successive revolutions, and parts of revolutions, of the disc, the total number of complete revolutions made being taken by reckoning the coils wound off the barrel. Upon a mean of ten experiments with this apparatus, the delay at the contact-maker appeared to be no more than  $0''\cdot0143$ , which converted into distance, at the greatest transit-rate observed, gives a correction of 17·3 feet per second, and at that of the least of 12·8 feet per second, both additive.

It may be remarked that the small error due to inertia, &c. in this apparatus tends nearly to correct itself, the extremely small time lost at starting of the disc being very nearly equalled by its tendency to be carried a little too far by the velocity impressed; the whole inertia also of the disc-barrel, &c. was extremely small in proportion to the moving weight W.

Another correction requiring to be attended to in these experiments was the *time of hang-fire* in the charge of the mine, that is to say, the time required for the burning of such a portion of the whole charge of powder as should be sufficient to rupture the rock around, and so start off from the focus the wave-impulse perceived in the seismoscope—in other words, the time lost between the instant of first ignition of the powder, viewed as simultaneous with that of making contact at the firing-battery B, and the starting of the wave of impulse to be measured.

In my former experiments at Killiney Bay, it will be recollected that it was in my power to determine this experimentally and rigidly, the moderate charges of powder there employed admitting of this, and that I found it amount for 25 lbs. of powder to  $0''\cdot050513$ , or to about  $\frac{1}{20}$ th of a second. Such is, in fact, the time that the full charge of a 68-pounder takes to burn. But in the present case direct experiment was impossible; and the value for this correction can only be approximately obtained, by observing the time that elapsed in some instances between the moment of making contact at B and the first great visible movement of rock at the face of the heading. This observation I

made in three instances, noting the time by a delicately made chronoscope by M. ROBERT, Rue du Coq, Paris. The results gave  $0''\cdot05$ ,  $0''\cdot04$ , and  $0''\cdot08$  for the time of hang-fire respectively, noting from the first visible movement of rock at the face of the heading. This would give a mean of  $0''\cdot0566$ , or very nearly  $0''\cdot06$  for the time of hang-fire, which can be viewed, however, only as an approximation. It must vary slightly with every different "heading," depending as it does upon a great variety of conditions, but probably much more upon the exact proportion subsisting in any given case between the actual resistance of the rock to the powder employed than upon the absolute quantity of the latter, although the total mass of powder burnt is also an element. The greatest *observed difference* between the greatest and least hang-fire amounted to  $0''\cdot03$ , which, converted into distance at the mean transit-rate of our experiments, would give a *possible* maximum error due to this cause of about 31 feet per second; the *probable* error cannot be more than about one-half that amount. This correction, converted into distance, is also *additive*.

By the methods thus described the experiments were commenced and conducted up to the middle of 1857. Great trouble and difficulty, however, were experienced from the outset in keeping the arrangements in working order and so as to be efficient when wanted at the very brief notice that could be afforded me beforehand by the officers in charge of the works, when suitable headings were about to be fixed. The entire line of telegraph wires, the observer's shed, &c., were exposed to mischief and depredation and to injury in that tempestuous place by storms, &c. The long intervals between the experiments involved preparations and adjustment of every part of the galvanic apparatus afresh; upon each occasion, and for the most trifling repairs, workmen had to be brought from Conway, or even from Manchester, as also, in every case, to make good the branch conductors from the telegraph wires. The length of the range and hilly character of the ground also produced much difficulty, in being assured that all was right from end to end against the moment at which the firing was obligatory, as well as great personal fatigue at a moment when composed ease and freedom from fatigue were most desirable for good observation.

These difficulties, in great part foreseen, had early caused me to turn my attention to the practicability of so adjusting, at the observing-station, a telescope of large field and clear definition, and so disposing the GROVE'S firing-battery and other apparatus at the quarry cliff, that all could be clearly seen from the former point, and the act of making contact at the firing-battery observed by myself with distinctness and certainty, the two extremities of the range being thus, as it were, visually brought together.

Two attempts to experiment in the summer and autumn of 1857, rendered abortive by derangements of the galvanic apparatus, caused me finally to abandon it, though unwillingly. I found, however, with some satisfaction, that, subject to the *possible* fatality of a cloud settling over the quarry cliff, and so shutting it out from sight just at the critical moment, the telescopic arrangement, on trial, really seemed to offer quite as accurate results as the more complex method, and more difficult to manage, of galvanic



contact-making; and the new mode was thus continued to the end of the experiments. The firing-battery being so disposed upon the sloping brow of the quarry cliff facing my station as to be clearly visible to me, as well as every movement of those employed there, a code of signals was arranged between myself and Mr. COUSENS, by which we should mutually become cognizant of the state of preparation, &c., and successive acts at our respective stations. When all was ready at both ends for the explosion, the final signal was made by Mr. COUSENS, by elevating a bright-red flag (mounted upon a short and light staff) to a vertical position, the lower end resting on a fixed point; a pre-arranged interval of a few seconds (usually 10") intervened, when he dropped the red flag, rotating it upon the lower end of the staff held in the right hand, and with the left made contact of the poles of the firing-battery at the same instant that the flag reached the horizontal position. Standing facing me, and as distinctly observable by me upon each occasion as though I had been close beside him, my own eye and attention were directed to Mr. COUSENS's left hand; at the instant that I observed the contact made by him I released my chronograph, and at once transferred my eye from the eyepiece of the observing telescope to that of the seismoscope. A moment elapsed before my own eye adjusted itself to the focus of the latter; but the length of transit-period of the wave (always above 4") gave ample time for this, and then at the disappearance of the cross wires, as in the former case, I arrested the chronograph. The only source of time-error introduced by this plan was that of the probability of some slight inequality of speed in dipping the poles to make contact, on Mr. COUSENS's part (which may be called his personal equation), and the introduction of a somewhat larger value than before to my own personal equation—in the former arrangement that being due to consent between my *hand* and observation by the *eye* of *one* object, in the latter, between the *hand* and observation of *two* objects.

As regards the first, several experiments were made by Mr. COUSENS and myself at the firing-station, by his repeatedly lowering the red flag and making (the movement of) contact, the contact-maker (fig. 2, Plate XXIII.) and chronograph being so arranged as to register the total interval of time, in each case, between the first visible motion of the red flag, and the completion of contact; others were so made as to register the time between the horizontal position of the red flag, and the completion of contact. The result gave a minimum error of 0".009, and a maximum of 0".017. The mean error, 0".013, is thus almost equal to the constant due to the contact-maker (in previous arrangement), with this difference, however, that the error in the present case *might* be either + or -. In twelve experiments, nine were + or additive; that is to say, the contact was made more slowly with the left hand than the flag was dropped with the right. The probability is therefore 3:1 that the error would be always additive, and would not exceed 0".013 even if my observation was wholly directed to the flag; but as I directed my attention as completely as possible only to the movement of the contact-making hand, it is still less, and therefore, as not amounting to more than 6 or 7 feet per second in transit-time, may be neglected altogether. As regards my own personal

equation of observation, it will be seen, on reference to "Second Report\*," &c., of the former experiments at Killiney, where it was ascertained for both observers, that its amount is much too minute to enter sensibly into the present results; and it is needless to say that this is *à fortiori* the case as respects the time lost in transmission of the galvanic current through the 12,000 or 13,000 feet of conducting-wire.

The diagrams (Plate XXII.) give, to one scale, horizontal sections of the several headings, from the experiments on which, transit-results have been deduced, and a vertical section also of No. 31, quarry No. 9, as illustrative in this respect of all the others.

The line of heading, from the face of the cliff up to any focus of charge, turns, it will be seen, thrice at right angles to itself, the object being more effectually to confine the effort of the powder when fired, and prevent the mass of "tamping" from being blown out. Results have been deduced from two headings, each of single focus; two of double focus, one of triple focus, and one of four foci,—the face of the cliff blown out varying (as marked in each case in the figure) from 60 feet to 120 feet in height, and the total weight of powder fired at one time being from 2100 lbs. up to the enormous charge of 12,000 lbs., or nearly 6 tons.

It was necessary to ascertain the exact distance in a right line from each of these headings, wherever situated, to the observing-station O, at Pen y Brin; and for this purpose, previously to each explosion, the distance of the mouth of the heading was measured with accuracy (which the ground admitted of) from the flagstaff at W (see Map, and Section I. Plate XXI.). The exact distance of the latter having been previously determined from the observing-station O, as already described, the angle of azimuth made at the flagstaff by the line of constant range (O W), and by the line joining the flagstaff and mouth of the heading, was observed in each case; and we thus had the requisite data, from which was calculated, by the usual formulæ,

$$\frac{1}{2}(A+B) = 90^\circ - \frac{1}{2}C,$$

$$\log \tan \frac{1}{2}(A-B) = \log (a-b) + \log \tan \frac{1}{2}(A+B) - \log (a+b),$$

C being the observed angle, *a* and *b* the known sides from flagstaff to O, and from flagstaff to the mouth of the heading.

Thus the actual range of wave-transit from the focus of each explosion to the seismoscope at O was finally obtained. The positions respectively of each are marked by a black dot, and numbered in order of the date of experiment upon the Map (Plate XX.), taken from M. RENDELL'S chart of 1850, published by the Admiralty. Upon it the measured base (A B) and triangulation for obtaining the constant range (O W), and for checking that measurement, are marked. The actual wave-paths are therefore in right lines, from the dots No. 1, No. 2, No. 3, &c., to the point O. The coast-line and position, approximately, of the cliff-faces of the quarries, and the superficial line of junction of the quartz rock and of the slate, are also marked. The great clay dyke passing

\* Report of British Association, 1851, p. 305, &c.

through the quartz rock at the quarries in rear of the headings is marked by a pair of interrupted lines.

The Map is to a scale of  $1\frac{1}{4}$  inch to 1000 feet, but is not quite exact as to filling in details on land. The important distances here concerned are therefore marked in by figures.

In the following Table our chief numerical results are comprised at one view.

TABLE I.—Wave-transit Period, Experimental Results. Holyhead.

1.	2.	3.	4.	5.	6.	7.	8.	9.	10.	11.
Date of firing heading.	Number of the heading.	Number of the quarry.	Weight of powder exploded.	Approximate weight of rock removed.	Total distance of mean centre of heading from observer.	Total observed time of transit.	Observed rate of transit per second, uncorrected.	First time correction for the seismoscope + in distance.	Transit-rate with first correction (col. 9).	No.
			lbs.	tons.	feet.	secs.	ft. per sec.	ft. per sec.	ft. per sec.	
1856, Nov. 13 ...	No. 46.	No. 9.	3,200	10,000	6582.93	7.346	896.12	58.248	954.368	1.
1856, Nov. 13 ...	No. 10.	No. 3.	2,100	7,500	5476.57	5.658	967.93	62.915	1030.915	2.
1857, May 16 ...	No. 31.	No. 9.	2,600	9,000	6377.14	6.524	977.26	63.522	1040.782	3.
1857, Dec. 18 ...	No. 33.	No. 9.	6,200	20,000	6403.48	5.455	1173.87	76.302	1250.172	4.
1860, Nov. 24 ...	No. 80.	No. 3.	12,000	36,000	5038.13	4.161	1210.79	78.701	1289.491	5.
1861, May 11 ...	No. 84.	No. 4.	4,400	13,000	5228.59	5.249	996.11	64.747	1060.857	6.

The first result that strikes the eye at once in regarding the preceding Table is, that, with the exception of the experiment No. 1, all show that the transit-rate tends to increase in velocity with the increased quantity of powder fired,—in other words, that the loss of velocity in the same rock is less, in some proportion, as the force of the originating impulse of the wave is greater, and its amplitude therefore greater on starting.

This is apparent if the uncorrected transit-rates (col. 8) be arranged in the order of increased weights of powder exploded, thus:

TABLE II.

Number of experiment ...	2	3	1	6	4	5
Weight of powder (lbs.) ...	2100	2600	3200	4400	6200	12000
Uncorrected transit-rate } (feet per second)	967.93	977.26	896.12	996.11	1173.87	1210.79

Experiment No. 1 forms the only exceptional case, and the departure is not a wide one; so that the result cannot be viewed as accidental, or due to any balancing of errors, but as the expression in so far of a fact of nature.

Nor is it due to relative differences of different experiments in the lengths of range, in the quartz rock and in the slate respectively, as might be imagined; for the experiments Nos. 2, 5, and 6 had wave-paths of about 1400 feet in quartz only, and embrace the lowest and the highest velocities, while Nos. 1, 3, and 4 had about double this range or wave-path in quartz, with velocities not widely different from each other, or from No. 2.

There are four corrections altogether applicable to the uncorrected transit-rates, col. 8, Table I., as already referred to, viz.—

1st. That for the liquid wave in the seismoscope, which, as a delay in *time*, is, when converted into distance, always +. This correction has been already applied in cols. 9 and 10, Table I.

2ndly. That for the *time* of hang-fire of each explosion in the rock; the constant in time for which has been given =  $0''\cdot056$ .

It appeared, however, uncertain whether this should be converted into distance, as probably nearly constant for every experiment, or in what way it might be variable, in relation to the weight of powder and other circumstances of each. The result disclosed in Table II., however, appears to indicate that the conversion into distance should be proportionate to the respective gross or uncorrected transit-rates, assuming, as we may now do, that these are functions of the originating impulses and resistances together, in each instance. This may not be absolutely true, but is the nearest approximation we can make. This correction in distance is also always +.

3rdly. The loss of time at making contact,—whether galvanically, in which we ascertained the constant in time to be =  $0''\cdot0143$ , when converted into distance always +; or by the hand (of the firing party), when we found it was in time =  $0''\cdot013$ , which in distance might be either + or —.

The probability being so much in favour of the latter being positive, I have ventured to apply it as always so, which also renders all the experiments more truly comparable.

4thly. The personal equations of the observer and time of transit of the galvanic current, both of which may be neglected.

Applying these several corrections, we obtain the following Table and final numerical results:—

TABLE III.—Wave-Transit Experiments. Corrected Results.

	1.	2.	3.	4.	5.
Number of experiment.	Observed rate of transit per second, uncorrected, col. 8, Tab. I.	2nd correction, for hang-fire of explosion taken in distance.	Transit-rate with 2nd correction, col. 2 + col. 10, Tab. I.	3rd correction, making contact, into distance.	Final corrected transit-rates, col. 3 + col. 4.
	feet per second.	feet per second.	feet per second.	feet per second.	feet per second.
1.	896·12	50·183	1004·551	11·649	1016·200
2.	967·93	54·204	1085·119	13·831	1098·950
3.	977·26	54·726	1095·508	13·975	1109·483
4.	1173·87	65·737	1315·908	15·260	1331·168
5.	1210·79	67·804	1357·295	15·740	1373·035
6.	996·11	55·792	1116·649	12·949	1129·598

The limits of error in these results would seem to be, that the 2nd correction *may* amount to 15·5 feet per second in excess, and the error from all other instrumental or observational sources may be estimated probably at not more than 10 feet per second, so that the results may be deemed true to within  $25\frac{1}{2}$  feet per second + or —.

The general mean derivable from the whole of the experiments taken together gives

1176·407 feet per second for the transit-rate. The results, however, obviously form two groups, viz. Nos. 1, 2, 3, and 6 from the smaller charges of powder, and Nos. 4 and 5 from the greater ones.

The mean from the four first is 1088·5597 feet per second, and that from the two last is 1352·1015 feet per second; and taking a mean of means from both of these, we obtain a final result of 1220·3306 feet per second as the mean transit-velocity of propagation, in the rocks experimented on, of a wave-pulse produced by the impulse of a charge not exceeding 12,000 lbs. of powder. We may be justified in concluding that the velocity of wave-propagation (or transit) really does increase with the force of the original impulse; it would be vain, however, to attempt to deduce the law of such increase from the results before us.

The experiments of Mr. GOLDINGHAM at Madras, on the retardation of sound in moist air, and the theoretical researches of Mr. EARNSHAW, both, by analogy, rendered *à priori* probable the fact itself, now for the first time, so far as I am aware, experimentally shown.

It follows, then, on reference to my former experiments at Killiney Bay, that the rate of wave-propagation in highly stratified, contorted and foliated rock is intermediate between that for dense wet sand and for discontinuous and shattered granite. Adopting the first mean from the smaller charges of powder, as better comparable with the Killiney experiments, which were made with charges of only 25 lbs. of powder, and which would doubtless have given higher velocities with heavier charges, we obtain the following series:—

Transit-rates of Wave-propagation.

In wet sand . . . . .	824·915 feet per second.
In contorted and stratified rock (quartz and slate)	1088·559 feet per second.
In discontinuous granite . . . . .	1306·425 feet per second.
In more solid granite . . . . .	1664·574 feet per second.

We may infer, even adopting the highest mean of these experiments, 1352·101 feet per second, for comparison with the transit-rate for discontinuous granite, and bearing in mind that the former velocity is due to the impulse originated by a *mean* charge of 9100 lbs. of powder, while the latter was due to one of but 25 lbs., that for equal originating impulses the rate of propagation of waves analogous to earthquake waves of shock must be less, generally if not always, in contorted stratified rocks than in crystalline igneous rocks analogous to granite, the amount of shattered discontinuity being the same in both.

The general mean obtained, viz. 1220·33 feet per second = 13·877 statute English miles per minute, coordinates, as might be expected, with the more trustworthy of the older attempts to determine the velocity of propagation of earthquake-waves in nature\*, and still more so with the more recent and exact determinations of such velocities made

\* See Table 8, "Second Report on Earthquakes," &c., Report of Brit. Assoc. 1851, p. 316.

by NÖGGERATH\*, who found it 1376 Paris feet per second; by SCHMIDT†, of the shock about Mincow in Hungary, and by myself in the (late) Neapolitan kingdom, after the great shock of 1857, where I found that the velocity of propagation, in the shattered limestone and argillaceous rocks of the shaken region, was even below what has been here determined for the harder and more compact rocks of Wales, also of stratified structure. Experiment and observation have thus alike sustained the three provisional conclusions anticipated by me as to the transit-velocities of earthquake waves in nature (at the conclusion of "Second Report," &c., Report of Brit. Assoc. 1851, p. 316), in passing through formations different in character.

In experimenting with these great explosions at Holyhead, I have been enabled to see that such great impulses, though offering the advantages of a greatly extended range, and hence larger total time-period for measurement, do not in reality admit, from various contingent circumstances, of greater, or perhaps of as great accuracy of transit determinations, as do much smaller explosions, such as those specially made at Killiney Bay. These great explosions, however, elicit phenomena visible in the seismoscope, which are too faint to be distinct when due to smaller charges, and which analogize closely with the succession of vibratory and wave movements observed in natural earthquakes. In the larger of these great explosions, as the impulsive wave approached the instrument, the previously steady reflected image of the cross wires did not at once disappear; the definition of the wires rapidly became obscured, the obscuration increasing for an instant to a flickering of the image, preceding its obliteration, at the same moment that the oscillation then communicated to the trough caused the mercury to sway from end to end, in a liquid wave, whose amplitude was sufficient to cause variable flashes of light to be transmitted to the eye, with the changing inclination of the reflecting-surface of the undulating mirror,—the image of the cross wires reappearing (but now oscillating with the movement impressed upon the mercury in the direction of the wave-transit) by passing through a second phase of flickering and vibration, but in the reverse order, before becoming perfect in definition as at the commencement.

I had thus presented visibly before me the "tremors" that nearly invariably are described as preceding and following the main shock and destructive surface movement in every great earthquake. The phenomena appear to be identical, however premature it may be to propose a precise and adequate explanation of their production.

There appear to be *three* elements upon which the wave-transmissive power of a rock formation mainly depends, viz. the modulus of elasticity of its material, the absolute range of its compression by a given impulse or impact, and the degree of heterogeneity and discontinuity of its parts. As has been already described, the range of wave-transit of these experiments passed through two rock formations, quartz and slate, differing in name, and in several respects in structure, yet very much alike, as has been remarked, in

\* Das Erdbeben vom 29 Juli, 1846, im Rheingebiet, &c. V. Dr. JAKOB NÖGGERATH. 4to. Bonn, 1847.

† Untersuchungen über das Erdbeben am 15 Jan. 1858. J. F. SCHMIDT, Astronom, Mittheilungen der Kais.-Königl. Geog. Gesellschaft, 11. Jahrgang, 1858.

intimate composition. It remains to show, experimentally, that they do not differ in these conditions of transmissive power, to such an extent as materially to affect the results.

If a perfectly elastic ball be dropped upon a mass of perfectly elastic rock, whose volume may be considered as infinite with respect to that of the ball, the latter will rebound to the height from which it descended; and if the same ball, though not perfectly elastic, be dropped in succession upon like masses of two different rocks, it will rebound from each to a height less than that from which it fell, and the value of which will depend mainly upon the elasticity, the depth of the impression, and the degree of discontinuity of the rocks respectively. We have therefore thus got the means of very simply determining, in a sufficiently approximate manner, the relation between the velocity of impact and that of recoil, a quantity that bears the most intimate relation to the wave-transmissive power of rocks or other like bodies. To conduct this experiment, I dropped an ordinary ivory billiard ball upon a number of different masses of the quartz rock, and also of the slate, both *in situ*, and upon very large isolated blocks, making the impacts both transverse to the stratifications and foliation and in the same planes as these, in both sorts of rock. The ball was dropped from a constant height of 5 feet above the point of impact, and beside a graduated scale held vertically by an assistant, by means of which, after a little practice, and skill in choosing by trial a point of impact from which the ball shall rebound vertically only, it is easy to observe with considerable accuracy the height to which it recoils, the eye being gradually brought to the same level as that to which the ball rises, so as to read the scale free from parallax.

If  $H$  and  $h$  be the height from which the ball has fallen and that to which it rebounds, then

$$\frac{\sqrt{2gh}}{\sqrt{2gH}} = \frac{v}{V} = R,$$

which may be viewed as a symbol of the above relation, and closely connected with the wave-retardations respectively. In the quartz rock I obtained the following results:—

From the hardest and densest blocks or masses, and edgeways to the lamination, the ball recoiled 2·33 feet;  $v$  is therefore  $=s\sqrt{h}=12\cdot251$  feet per second.

From the softer and more earthy masses, and transverse to the planes of lamination, the recoil was 1·50 feet, and  $v=9\cdot822$  feet per second.

And in the slate rock,—

From the hardest and densest, edgeways to the foliation, the ball recoiled 2·00 feet, or  $v=11\cdot341$  feet per second.

From the least hard and dense, and transverse to the planes of foliation, the recoil was 1·417 feet, and  $v=9\cdot546$  feet per second.

The mean value for the quartz rock is thus

$$v = \frac{12\cdot251 + 9\cdot822}{2} = 11\cdot036 \text{ feet per second;}$$

and for the slate rock,

$$v = \frac{11\cdot341 + 9\cdot546}{2} = 10\cdot443 \text{ feet per second;}$$

and as  $H=5$  feet,  $V=17.935$  feet per second, we have

$$R_s = \frac{10.443}{17.935} = 0.576 \text{ for the slate,}$$

and

$$R_q = \frac{11.036}{17.935} = 0.558 \text{ for the quartz,}$$

numbers which differ so slightly from equality, as to indicate that there is no great difference of transmissive power in the two rocks. Indeed this is rendered certain by consideration of the experiments themselves. Previously to their commencement I expected that in every instance the range in quartz would have been extremely short in relation to that in slate, and very nearly the same in all cases. The circumstances of the works subsequently obliged me to increase the range in the quartz, and to adopt "headings" for experiment, three of which have a range in quartz of nearly double that of the other three, as seen in the two following Tables.

TABLE IV.—Shortest Ranges in Quartz.

No. of experiment.	Uncorrected transit-rate.	Range of quartz.	Range of slate.
	feet per second.	feet.	feet.
2	967.93	1600	3877
5	1210.79	1300	3738
6	996.11	1400	3829
Uncorrected mean transit-rate of Nos. 2, 5, 6.....1058.27 feet per second.			
Ratio of ranges in quartz to slate..... 1 : 2.66.			

TABLE V.—Longest Ranges in Quartz.

No. of experiment.	Uncorrected transit-rate.	Range of quartz.	Range of slate.
	feet per second.	feet.	feet.
1	896.12	2850	3733
4	1173.87	2700	3704
3	977.26	2650	3727
Uncorrected transit-rate, mean of Nos. 1, 4, 3.....1015.75 feet per second.			
Ratio of ranges in quartz to slate..... 1 : 1.32.			

In each of the two groups everything is as nearly as possible alike; there are two explosions of moderate charges, and one great explosion in each; they differ only in this, that in the first group, (Table IV.) the range in quartz, in proportion to that in slate, is very nearly double that in the latter (Table V.), being in the ratio of 2.66 : 1.32; yet, as will be observed, the mean transit-rate in both groups is almost alike, being in the ratio of 1058.27 : 1015.75. This would be obviously impossible, if either one rock or the other exercised any well-marked accelerating or retarding influence upon the transmission of the wave.

I hope shortly to be able to lay before the Society the results of some experiments upon the modulus of elasticity of perfectly solid portions of both these rocks, with



a view to the interesting question of the relation between the theoretic velocity of transmission, if the rock were all solid and homogeneous ( $V = \sqrt{2q \frac{\epsilon}{2}}$ ,  $\epsilon$  being that modulus), and the actual velocity found by the preceding experiments.

In their direct relation to Seismology the interest of the foregoing results is not as great as when some years since I commenced these experiments. At that period no knowledge whatever existed as to the relation that subsists in nature between the velocity of transit and the velocity of the particles in wave-movement in actual earthquakes. Geological observers, in fact, did not appear to be aware of any such physical distinction; and those who were so, presumed that the velocity of the particles was like that of transit, extremely great, and that some simple relation would probably be found between them.

The first determinations of velocity of the particles in wave-movement that have ever been made, namely, those by myself of the great Neapolitan Earthquake of 1857, have dissipated this notion, however, and proved that the velocity of the particles in even the greatest shocks, is extremely small, not exceeding 20 feet per second in very great earthquakes, and probably never having reached 80 feet per second in any shock that has occurred in history. No simple relation appears as yet between the transit-velocity and that of the particles; and, however interesting and important both to general physics and to Seismology may be further determinations with exactness of the former, it is to the observation and measurement of the latter, by the methods pointed out in the Report upon the Neapolitan Earthquake\*, and there employed, that we must look as instruments of future seismological research.

\* Now in the press. CHAPMAN and HALL, London: 2 vols. 8vo.

# HOLYHEAD HARBOUR

FROM THE  
PLANS, DRAWINGS & SOUNDINGS  
OF  
I. M. RENDEL C.E.  
1850.

1..... } Fathoms line { 3.....  
2..... } } 5.....  
Dry at low water

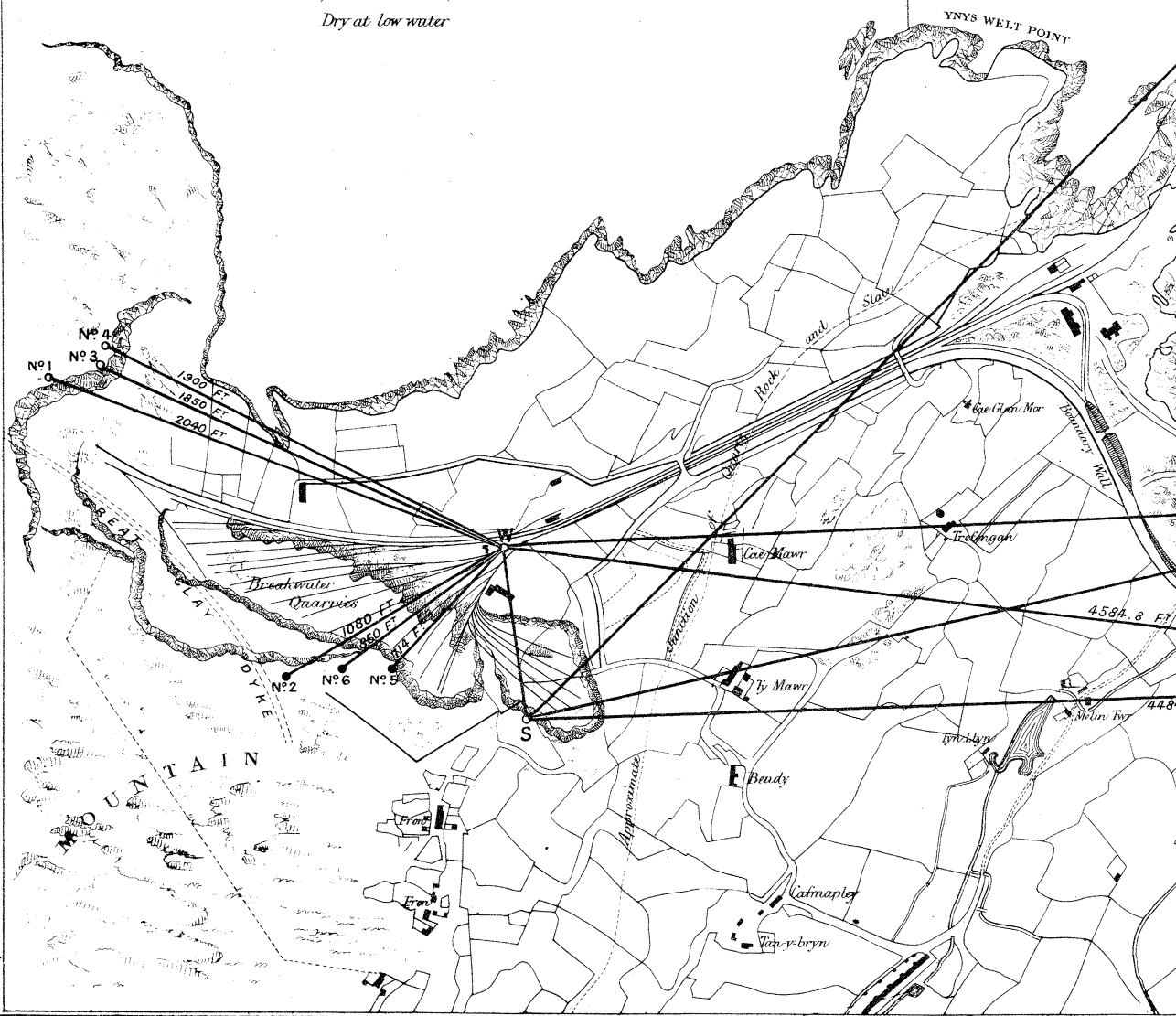
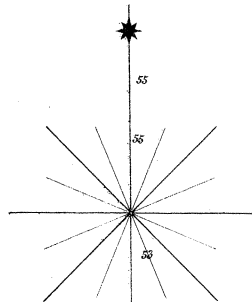

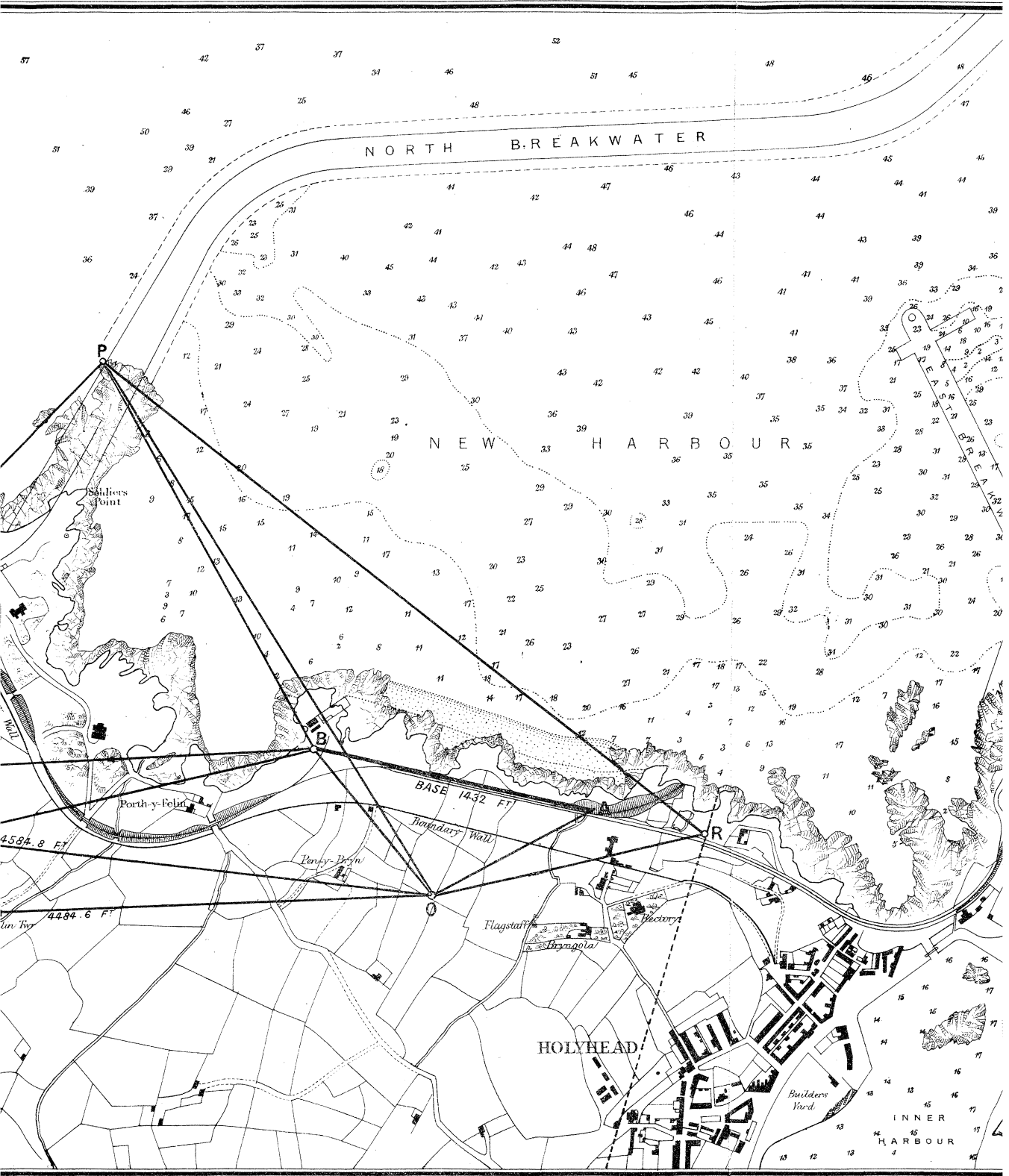

Half Nautic Mile.



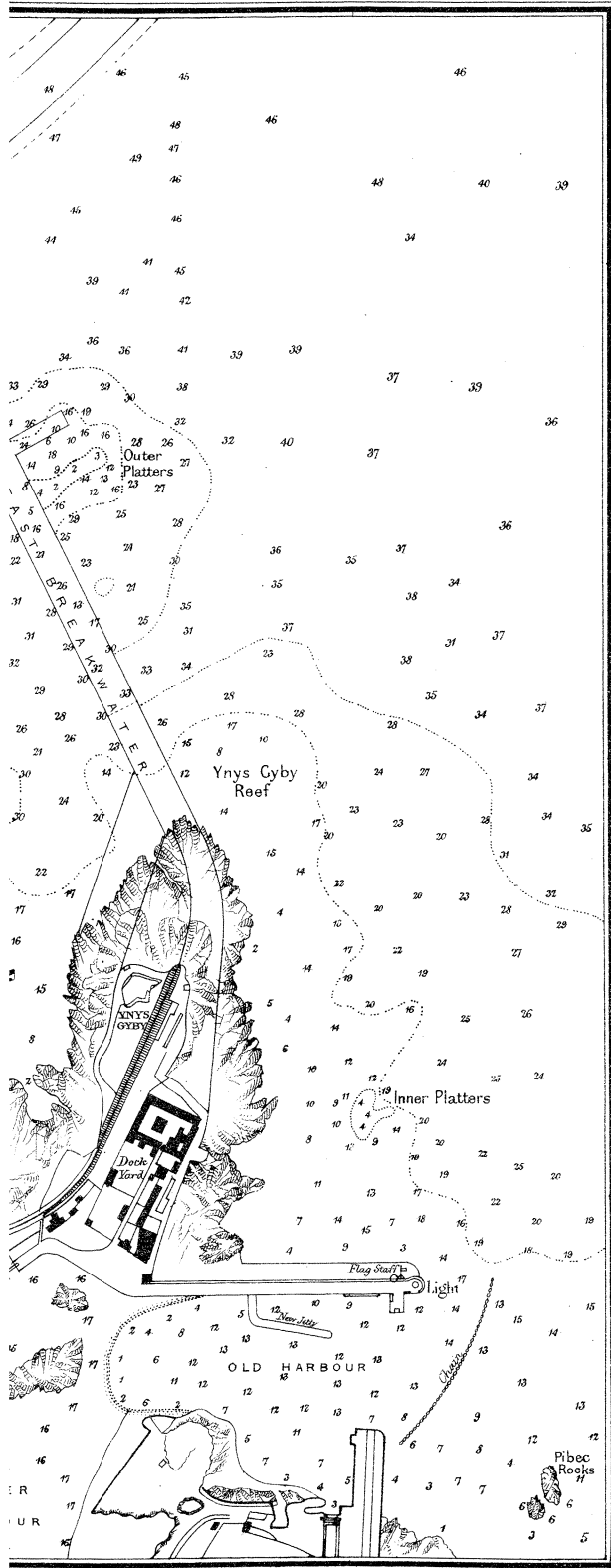

EARTHQUAKE EXPERIMENTS, HOLYHEAD QUARRIES.

Section of surface O to F of Map and Geological Section of Range.

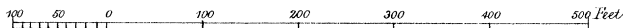
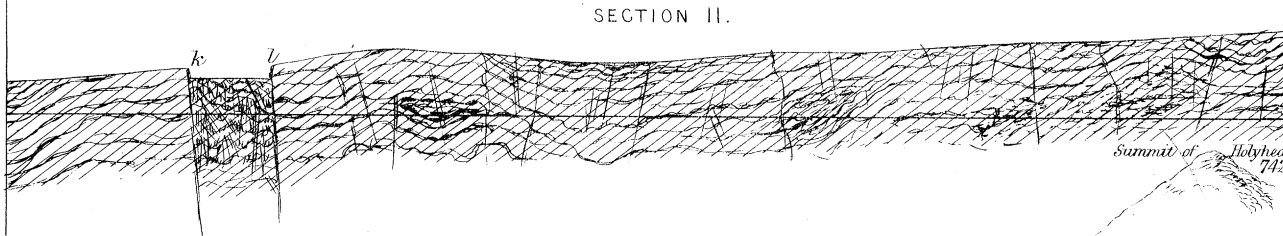
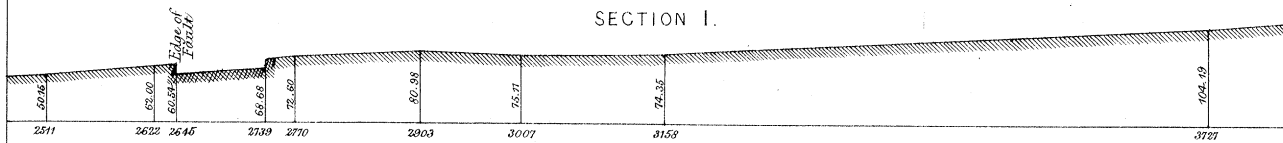
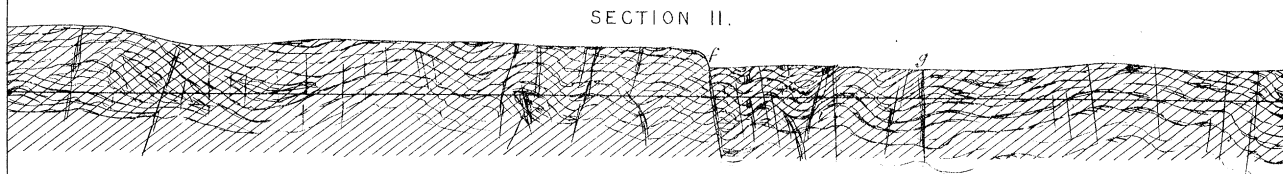
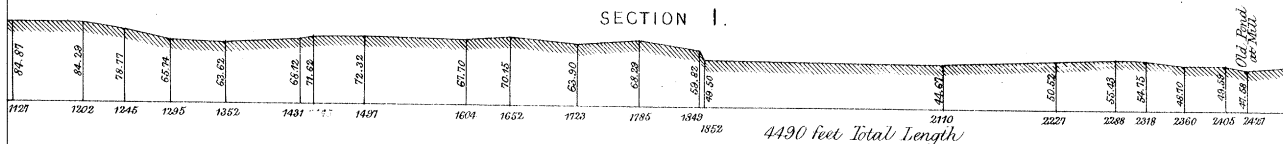
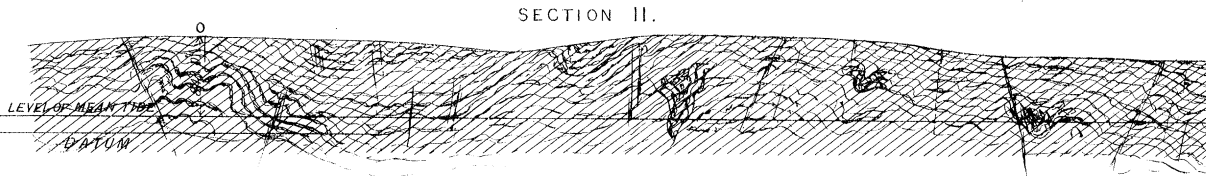
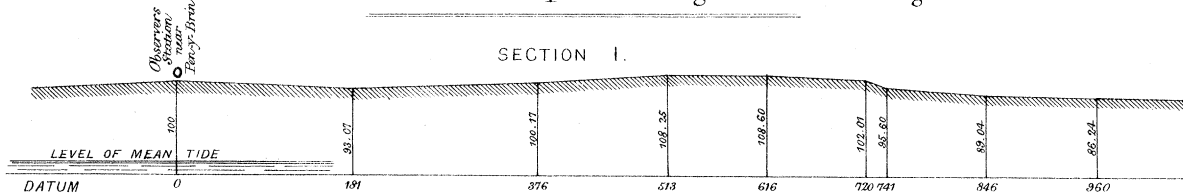

Scale 100 feet to 1/2 Inch. Vertical & Horizontal

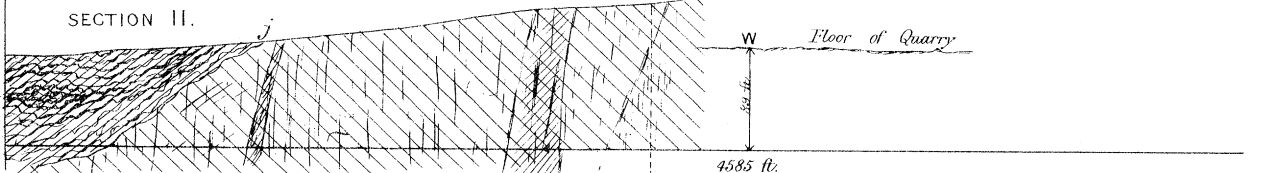
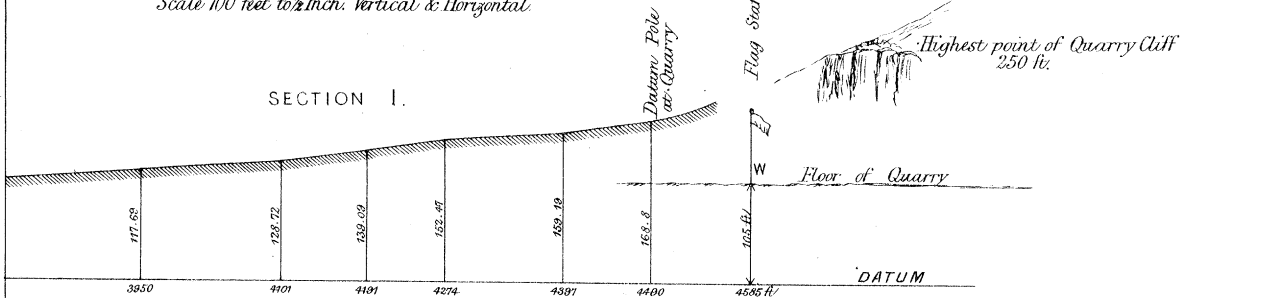

Exper. I. Heading N<sup>o</sup> 46. Fishers Quarry  
Face of Cliff. 120 feet in height.

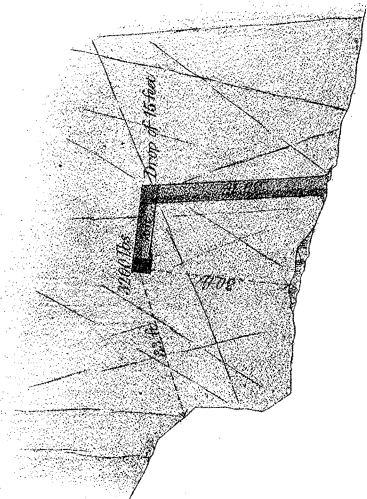

Exper. II. Heading N<sup>o</sup> 10. Quarry N<sup>o</sup> 3.  
Face of Cliff. 100 feet in height.

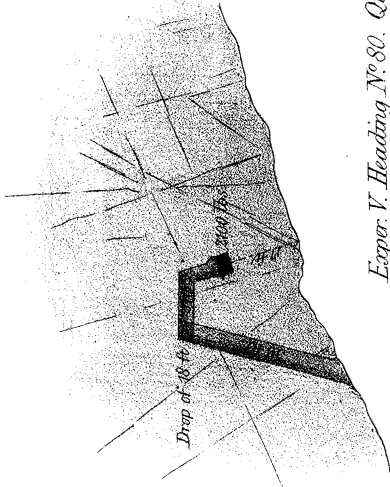

Exper. III. Heading N<sup>o</sup> 31. Quarry N<sup>o</sup> 9.  
Face of Cliff. 60 feet in height.

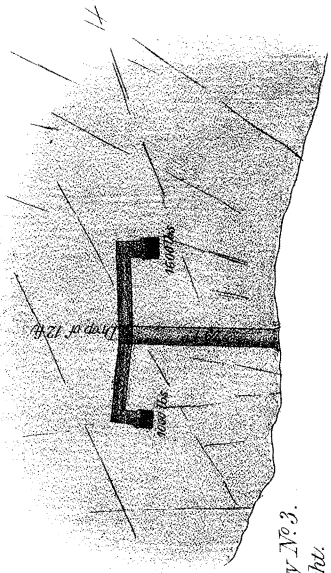

Exper. IV. Heading N<sup>o</sup> 33. Quarry N<sup>o</sup> 9.  
Face of Cliff. 115 feet in height.

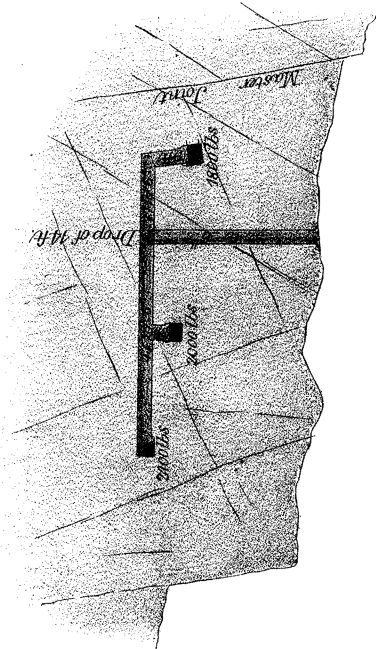

Exper. V. Heading N<sup>o</sup> 80. Quarry N<sup>o</sup> 3.  
Face of Cliff. 90 feet in height.

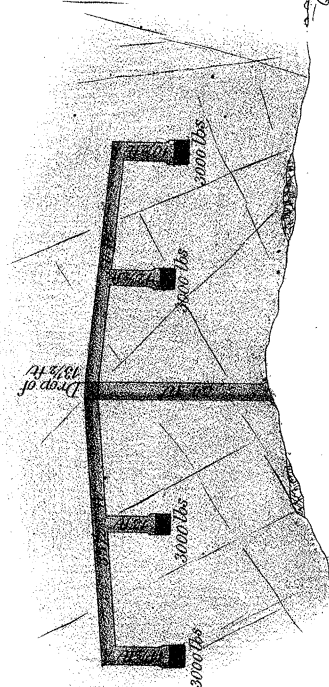

Exper. VI. Heading N<sup>o</sup> 84. Quarry N<sup>o</sup> 4.  
Face of Cliff. 85 feet in height.

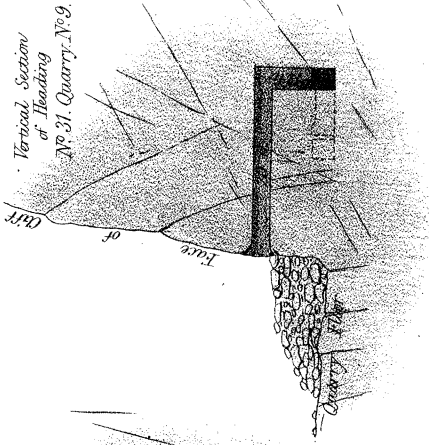
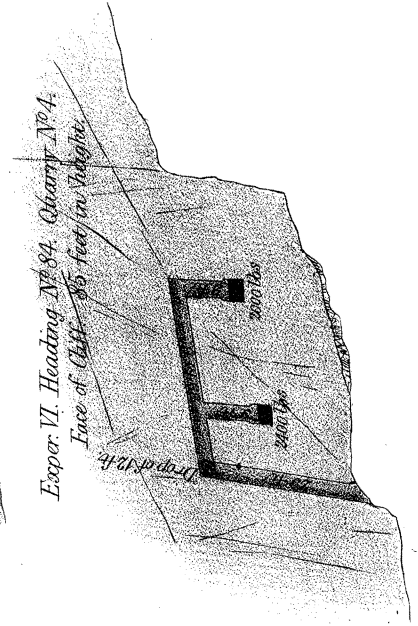

HORIZONTAL AND VERTICAL SECTIONS  
OF THE  
SEVERAL HEADINGS EXPERIMENTED UPON  
AT THE GOVERNMENT QUARRIES,  
HARBOUR WORKS, HOLYHEAD.

Elevation of the Contact Maker.

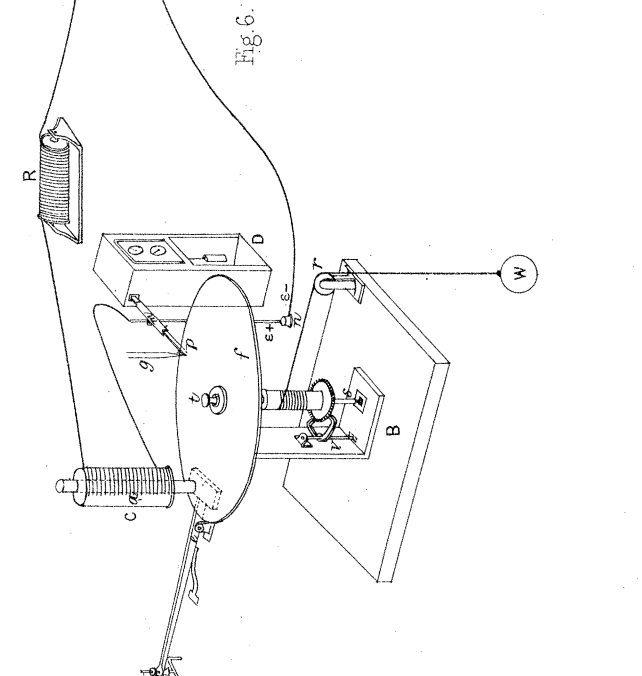
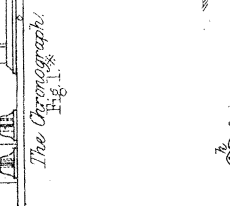
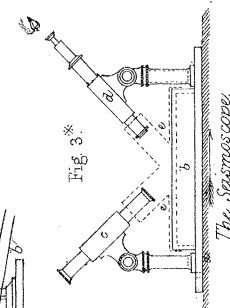
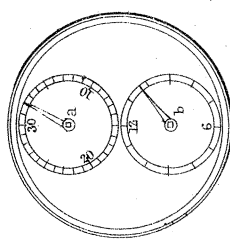
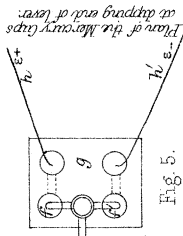
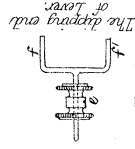
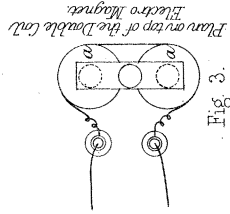
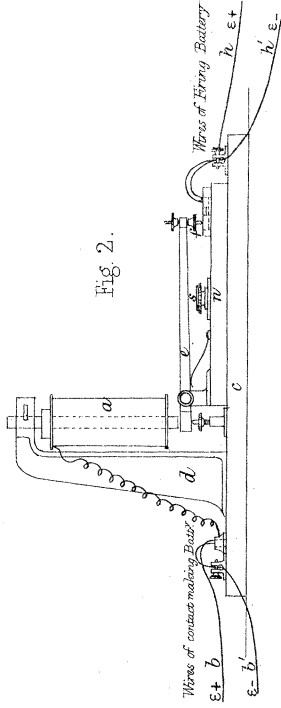
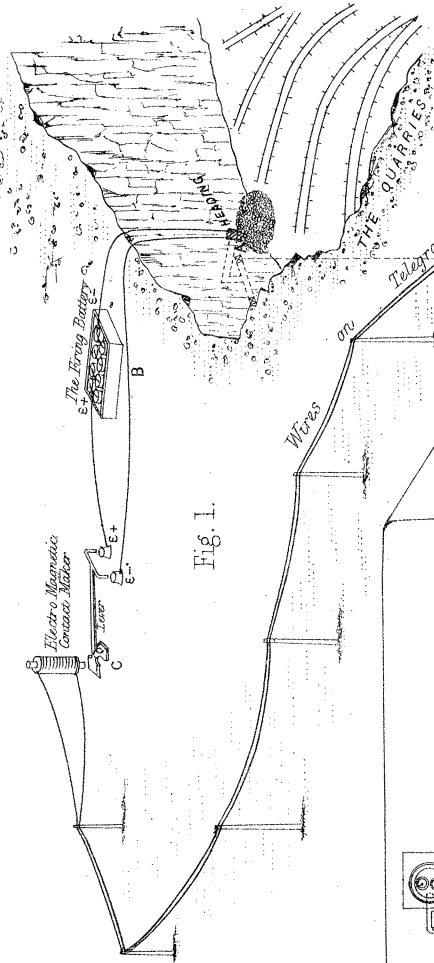

All on the Solid Rock, at the Observers Station.

# HOLYHEAD HARBOUR

FROM THE  
PLANS, DRAWINGS & SOUNDINGS  
OF  
I. M. RENDEL, C. E.  
1850.

1 ———— 2  
2 ———— 6  
} Fathoms line }  
Dry at low water

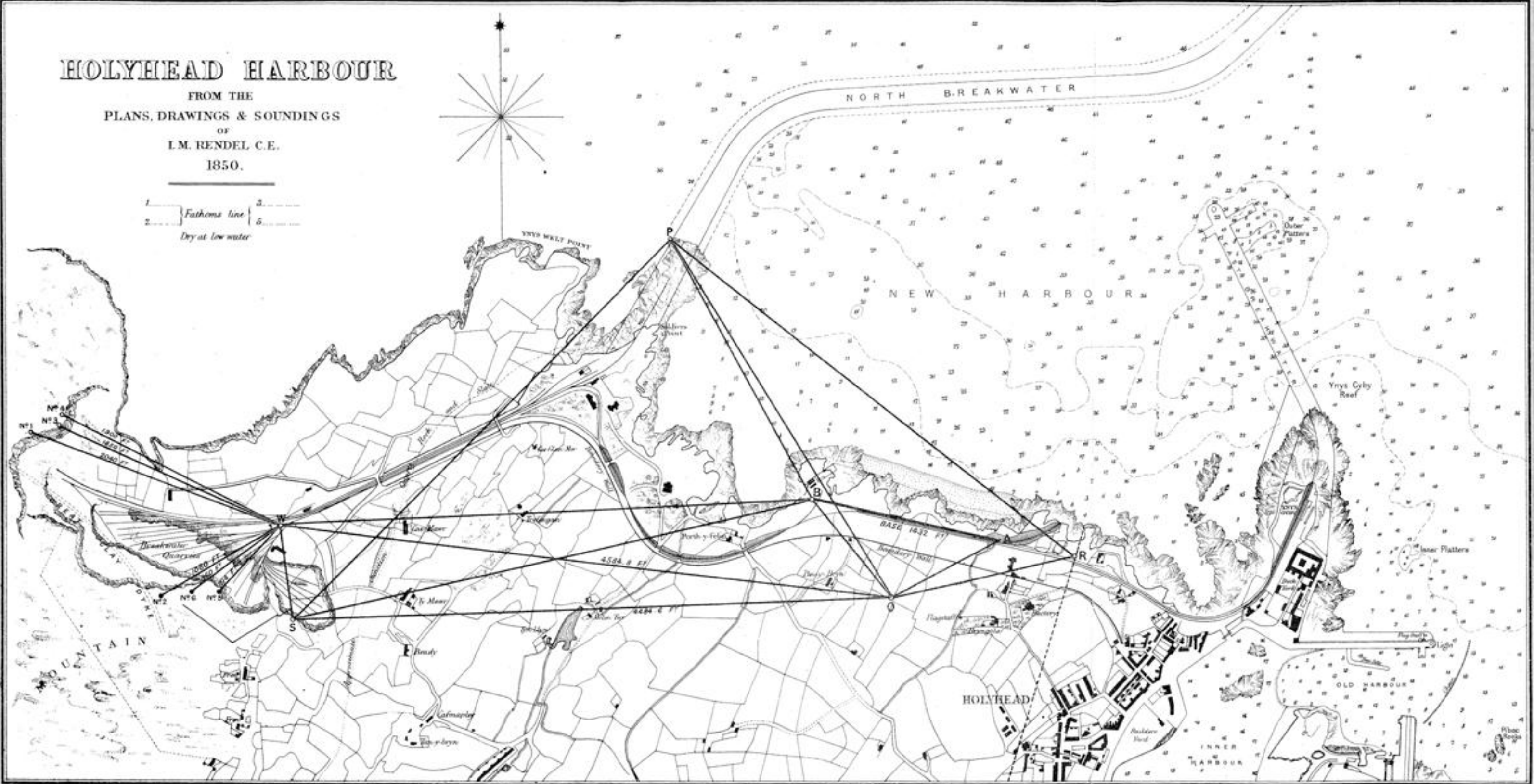

Half Nautic Mile.  
0 1 2 3 4 5  
Cable